



User Guide

Frequency Standard QFS-106

Model QFS-106

P/N 0150060XX

Revision E

July 2023

Brandywine Communications
1153 Warner Ave
(714) 755 1050
(714) 755 0175

<http://www.brandywinecomm.com>

INFORMATION TO THE USER FOR CLASS A DIGITAL DEVICE

WARNING: This equipment has been tested and found to comply with the limits for Class A digital device pursuant to Part 15 of the FCC Rules. These limits are designed to provide reasonable protection against harmful interference when the equipment is operated in a commercial environment. This equipment generates, uses, and can radiate radio frequency energy and, if not installed and used in accordance with the instruction's manual, may cause interference to radio communications. Operation of this equipment in a residential area is likely to cause interference in which case the user will be required to correct the interference at his own expense.

The user is cautioned that changes and modifications made to the equipment without approval of the manufacturer could void the user's authority to operate this equipment.



Revision History

REVISION	DATE	COMMENTS	ECO NUMBER
NC	10-26-04	Original release of QFS-106 user guide.	-
A	12-14-04	Revision of the rear panel and mechanical outline drawings.	-
B	08-03-05	Revision of Section 3.1.	-
C	02-14-11	Illustrations of fuse installation	-
D	10-24-17	Corrected Fuse Ratings	-
E	07-06-23	Added drawings directly into document file	ECO12672



Table of Contents

1	Overview	5
1.1	Part Number Reference	5
2	Specifications	6
2.1	I/O and Environmental (Rear Panel)	6
2.2	Switch and Indicator (Front Panel)	7
3	Unpacking and Installation	8
3.1	Unpacking	8
3.2	Installation	8
3.3	Connections	8
4	Operation	10
4.1	Powering the QFS-106	10
4.2	Loss of Input Signal	10
4.3	Loss of Output Signal	10
5	Calibration	11
6	Diagrams	12
6.1	Front Panel Drawing	13
6.2	Rear Panel Drawing (AC Model)	14
6.3	Rear Panel Drawing (DC Model)	15
6.4	Mechanical Outline Drawing (AC Model)	16
6.5	Mechanical Outline Drawing (DC Model)	17
6.6	Opened fuse housing (AC Model)	18
6.7	Fuse being removed (AC Model)	19
6.8	Detail of fuse installed (AC Model)	20

Table of Figures

Figure 1.	QFS-106 Front Panel Drawing	13
Figure 2.	Rear Panel Drawing (AC Model)	14
Figure 3.	Rear Panel Drawing (DC Model)	15
Figure 4.	Mechanical Outline Drawing (AC Model)	16
Figure 5.	Mechanical Outline Drawing (DC Model)	17
Figure 6.	Opened Fuse Housing (AC Model)	18
Figure 7.	Fuse Being Removed (AC Model)	19
Figure 8.	Detail of Fuse Installed (AC Model)	20



1 Overview

The Brandywine Communications QFS-106 is a high performance reference frequency standard distribution amplifier. The QFS-106 has two internal reference oscillator options. The QFS-106 may use either a free running Oven Controlled Crystal Oscillator (OCXO) or a free running Rubidium Oscillator. Also, the QFS-106 has various power supply options. The QFS-106 may use either AC or DC input power supplies. The QFS-106 provides six output channels of a single reference frequency, typically 10 MHz. The QFS-106 has six individually buffered low phase noise outputs. When more outputs are required, multiple QFS-106 units may be daisy-chained to a single reference.

1.1 Part Number Reference

PART NUMBER	OSCILLATOR	POWER SUPPLY
015006001	OCXO	115/230 VAC
015006002	OCXO	09 – 18 VDC
015006003	OCXO	18 – 36 VDC
015006004	OCXO	36 – 72 VDC
015006011	Rubidium	115/230 VAC
015006012	Rubidium	09 – 18 VDC
015006013	Rubidium	18 – 36 VDC
015006014	Rubidium	36 – 72 VDC

2 Specifications

2.1 I/O and Environmental (Rear Panel)

SPECIFICATION	DESCRIPTION	
Internal Reference Oscillator	OCXO Stability	1 x 10 ⁻⁸ at -30° to -60°C
	OCXO Aging	5 x 10 ⁻⁸ per year
	Rubidium Stability	±1 x 10 ⁻¹⁰ at 0 to 50°C
	Rubidium Aging	5 x 10 ⁻¹¹ per month
Reference Input	Label	J8
	Number of Reference Inputs	1 Input
	Frequency	10 MHz Standard
	Level	1 Vrms into 50 ohm
	Connector	BNC
Reference Output (Buffered from Reference Input)	Label	J7
	Number of Reference Outputs	1 Output
	Frequency	10 MHz Standard
	Level	1 Vrms into 50 ohm
	Distortion	< 33 dBc
	Connector	BNC
Outputs	Label	Output 1 (J1), Output 2 (J2), Output 3 (J3), Output 4 (J4), Output 5 (J5), and Output 6 (J6)
	Number of Frequency Outputs	6 Buffered Outputs
	Frequency	10 MHz Standard
	Level	1 Vrms into 50 ohm
	Distortion	< 33 dBc
	Connector	BNC
Phase Noise at 10 MHz	1 Hz	-90 dBc/Hz
	10 Hz	-110 dBc/Hz
	100 Hz	-140 dBc/Hz
	1000 Hz	-150 dBc/Hz
	10000 Hz	-157 dBc/Hz
Environmental	Temperature	-30 to +60°C
	Humidity	95% non-condensing
Fuse	VDC Model	400 VDC and 4A
	VAC Model	115/230 VAC and 250mA
Power	VDC Power Supply	09 – 18 VDC (12V Nominal)
		18 – 36 VDC (28V Nominal)
		36 – 72 VDC (48V Nominal)
	VAC Power Supply	115/230 VAC
Power Connection	VDC Connector	DC Connector
	VDC Connector 2 Pin	Pin A -> Positive
		Pin B -> Negative
	VAC Connector	AC Connector
Dimension	Length (Rack Mount & Chassis)	19.00" and 17.00"
	Height	1.720"
	Width	6.150"
Weight	Weight	Typically 3 lbs



2.2 Switch and Indicator (Front Panel)

SWITCH/INDICATOR	COLOR	DESCRIPTION
POWER SWITCH	—	Used to switch the unit on and off
POWER LED	GREEN	Indicates that the unit has primary power
OUTPUT MONITOR 1 LED	GREEN	Indicates that Output 1 is present
OUTPUT MONITOR 2 LED	GREEN	Indicates that Output 2 is present
OUTPUT MONITOR 3 LED	GREEN	Indicates that Output 3 is present
OUTPUT MONITOR 4 LED	GREEN	Indicates that Output 4 is present
OUTPUT MONITOR 5 LED	GREEN	Indicates that Output 5 is present
OUTPUT MONITOR 6 LED	GREEN	Indicates that Output 6 is present
PLL LED	RED	Indicates that the unit is in power up mode or not locked to the reference input
	GREEN	Indicates that the unit is phased locked to the reference input
RB LOCKED LED	GREEN	Indicates that the rubidium oscillator has reached resonance lock if installed
CALIBRATE (POTENTIOMETER)	—	Used to calibrate the oscillator

3 Unpacking and Installation

3.1 Unpacking

Carefully remove the QFS-106 from the shipping carton. The following items should be included in the shipment:

- 1 QFS-106
- 1 user guide
- 1 power cord
- 1 power mating connector (DC voltage only)

Note the power connection on the rear of the QFS-106 chassis. Please take note of the voltage displayed near this power connection.

If the AC or DC voltage setting is incorrect, use a small screw driver to remove the fuse holder. Reverse the fuse holder and re-insert the fuse holder, making sure that the correct AC or DC voltage is now displayed on the rear panel of the QFS-106.

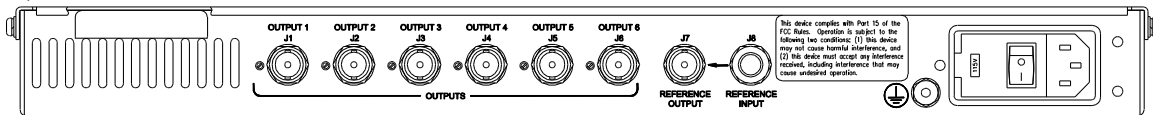

Use the supplied power mating connector for the QFS-106 unit (DC voltage only). The user must connect the wires to the connector as shown in the table below.

DC MODEL	DESCRIPTION
Pin A	Positive input voltage
Pin B	Negative input voltage
Mating Connector	Amphenol 97-3106A-10SL-4S
Strain Relief	Amphenol 97-3057-1004-1

3.2 Installation

The QFS-106 may be bolted directly onto a 19" rack mount enclosure.

3.3 Connections

Connect the power source to the QFS-106. Now connect the input reference signal and output reference signals to the appropriate connectors on the rear panel of the QFS-106. The Reference Output connector may be used when daisy-chaining multiple QFS-106 units.

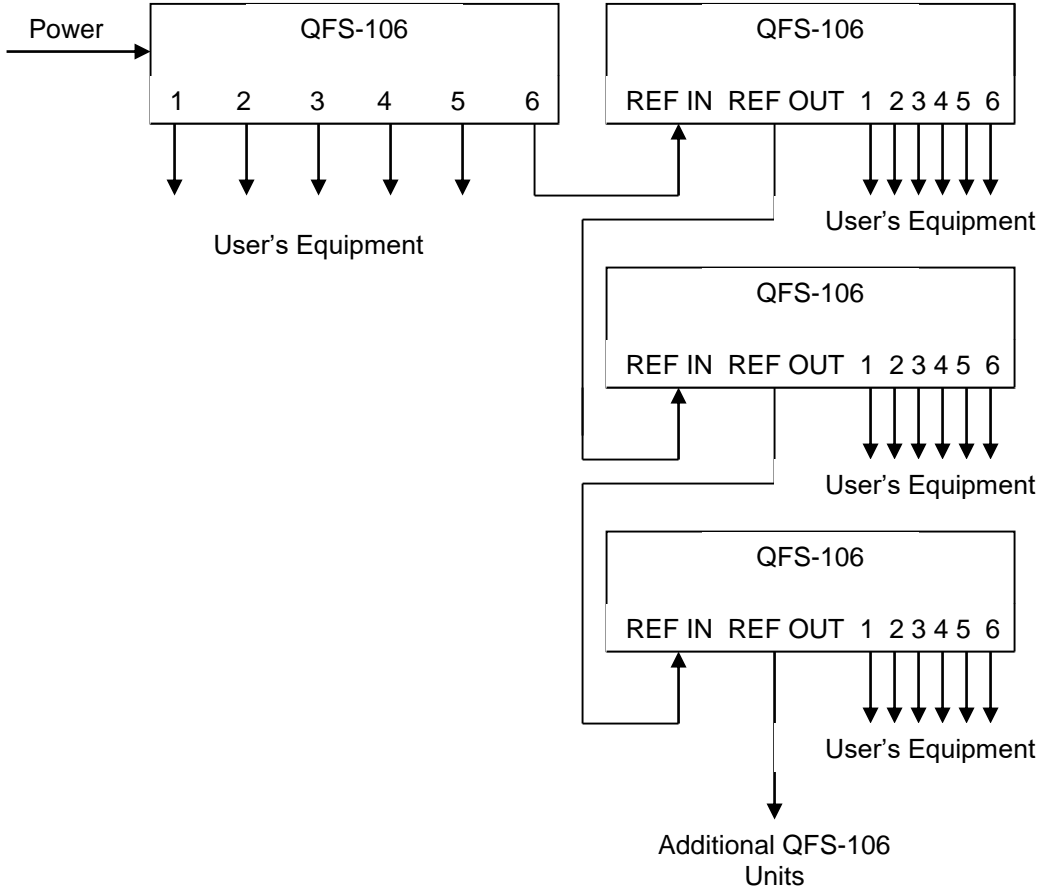

Figure 1 Daisy-Chain Interconnection

When daisy-chaining multiple QFS-106 units, these units should be connected as shown in Figure 1. This configuration ensures that all outputs are accurately locked to a common reference with minimal injection of the phase lock loop noise.



4 Operation

4.1 Powering the QFS-106

Once all the connections to the QFS-106 have been made, apply power to the unit by switching the power switch to the on position. The power switch is located on the rear panel of the unit. The Power LED and Output Monitor LEDs (1 – 6) on the front panel of the unit will illuminate green.

Please note that units fitted with the quartz oscillators will take approximately five minutes to warm up and these units will reach full accuracy after twenty-four hours. Units fitted with the rubidium oscillators will take approximately ten minutes to warm up.

4.2 Loss of Input Signal

The PLL LED illuminates green when an input signal is present on the Reference Input connector on the rear panel of the unit. If the reference input fails, the front panel PLL LED will extinguish.

4.3 Loss of Output Signal

The Output Monitor LEDs (1 – 6) illuminate green when output signals are present on the Outputs connectors on the rear panel of the unit. If one or more outputs fail, the front panel Output Monitor LEDs (1 – 6) will extinguish.

Please note that a short circuit on the output cable may not always trigger the output alarm.

5 Calibration

The QFS-106 is a free running standard that requires periodic recalibration. The unit must be calibrated against a frequency standard that is at least ten times more accurate than the oscillator fitted in the QFS-106 unit. Therefore OCXO oscillator units must be calibrated against a rubidium reference. Rubidium oscillator units must be calibrated against a cesium frequency standard or GPS disciplined rubidium. The front panel mounted potentiometer is used to adjust the frequency of the QFS-106 unit. The table below describes this calibration.

OUTPUT	POTENTIOMETER	OUTPUT LEVEL ADJUSTMENT
Calibrate	20 turn potentiometer (front panel)	Frequency standard calibration
Output 1	10 turn potentiometer (rear panel)	7 – 13 dBm
Output 2	10 turn potentiometer (rear panel)	7 – 13 dBm
Output 3	10 turn potentiometer (rear panel)	7 – 13 dBm
Output 4	10 turn potentiometer (rear panel)	7 – 13 dBm
Output 5	10 turn potentiometer (rear panel)	7 – 13 dBm
Output 6	10 turn potentiometer (rear panel)	7 – 13 dBm

6 Diagrams

FIGURE	DESCRIPTION
1-Page 13	QFS-106 Front Panel (AC and DC Models)
2-Page 14	QFS-106 Rear Panel (AC Model)
3-Page 15	QFS-106 Rear Panel (DC Model)
4-Page 16	QFS-106 Mechanical Outline (AC Model)
5-Page 17	QFS-106 Mechanical Outline (DC Model)
6-Page 18	Opened fuse housing (AC Model)
7-Page 19	Fuse being removed (AC Model)
8-Page 20	Detail of fuse installed (AC Model)

6.1 Front Panel Drawing

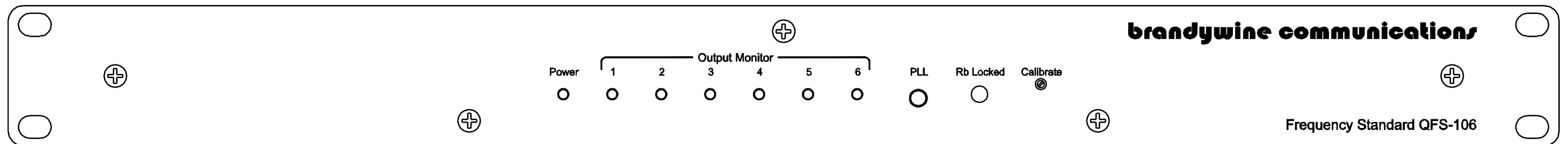

Figure 1. QFS-106 Front Panel Drawing

6.2 Rear Panel Drawing (AC Model)

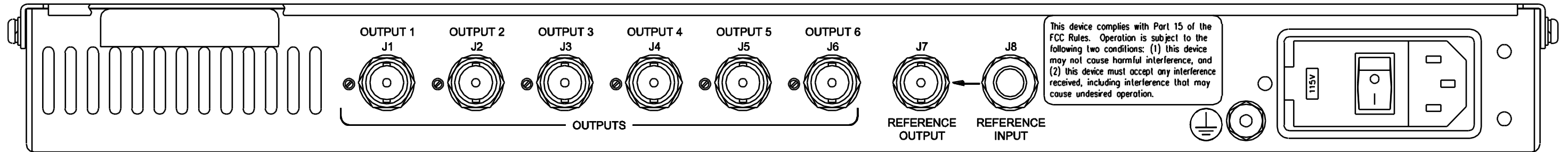

Figure 2. Rear Panel Drawing (AC Model)

6.3 Rear Panel Drawing (DC Model)

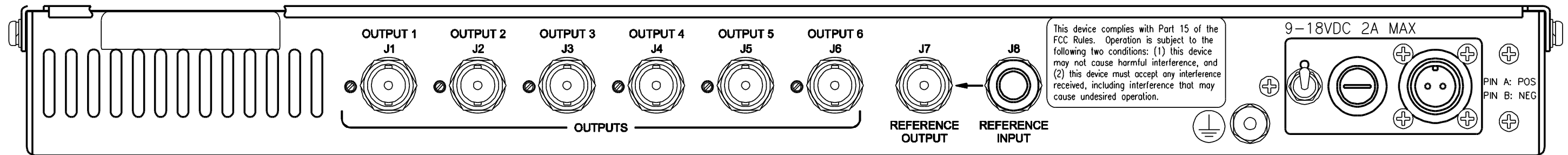

Figure 3. Rear Panel Drawing (DC Model)

6.4 Mechanical Outline Drawing (AC Model)

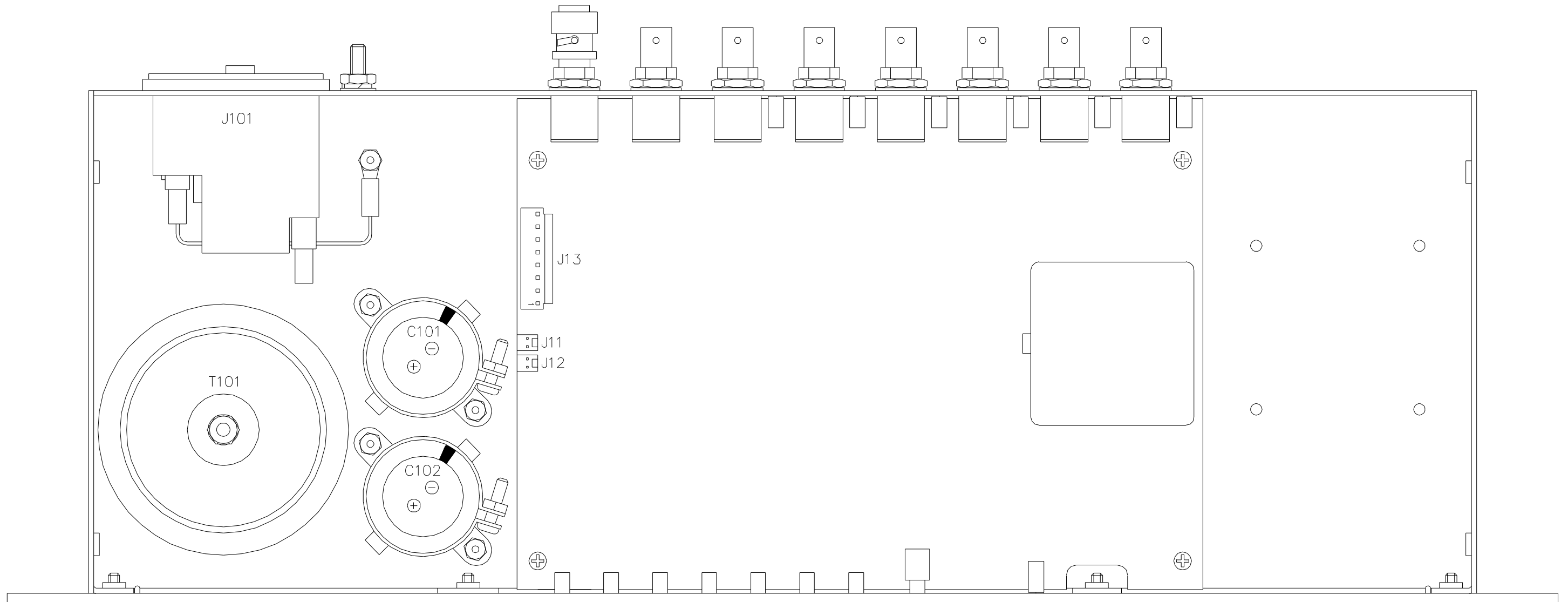

Figure 4. Mechanical Outline Drawing (AC Model)

6.5 Mechanical Outline Drawing (DC Model)

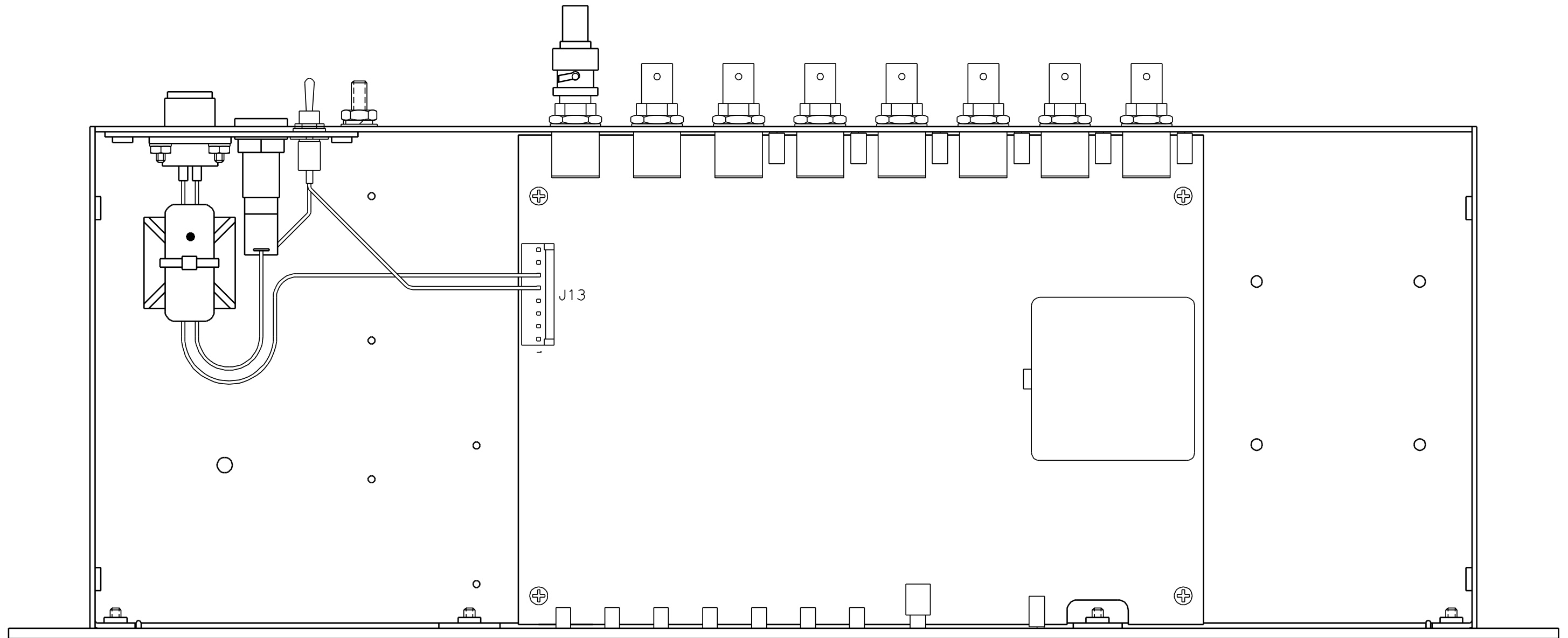

Figure 5. Mechanical Outline Drawing (DC Model)

6.6 Opened Fuse Housing (AC Model)



Figure 6. Opened Fuse Housing (AC Model)

6.7 Fuse Being Removed (AC Model)

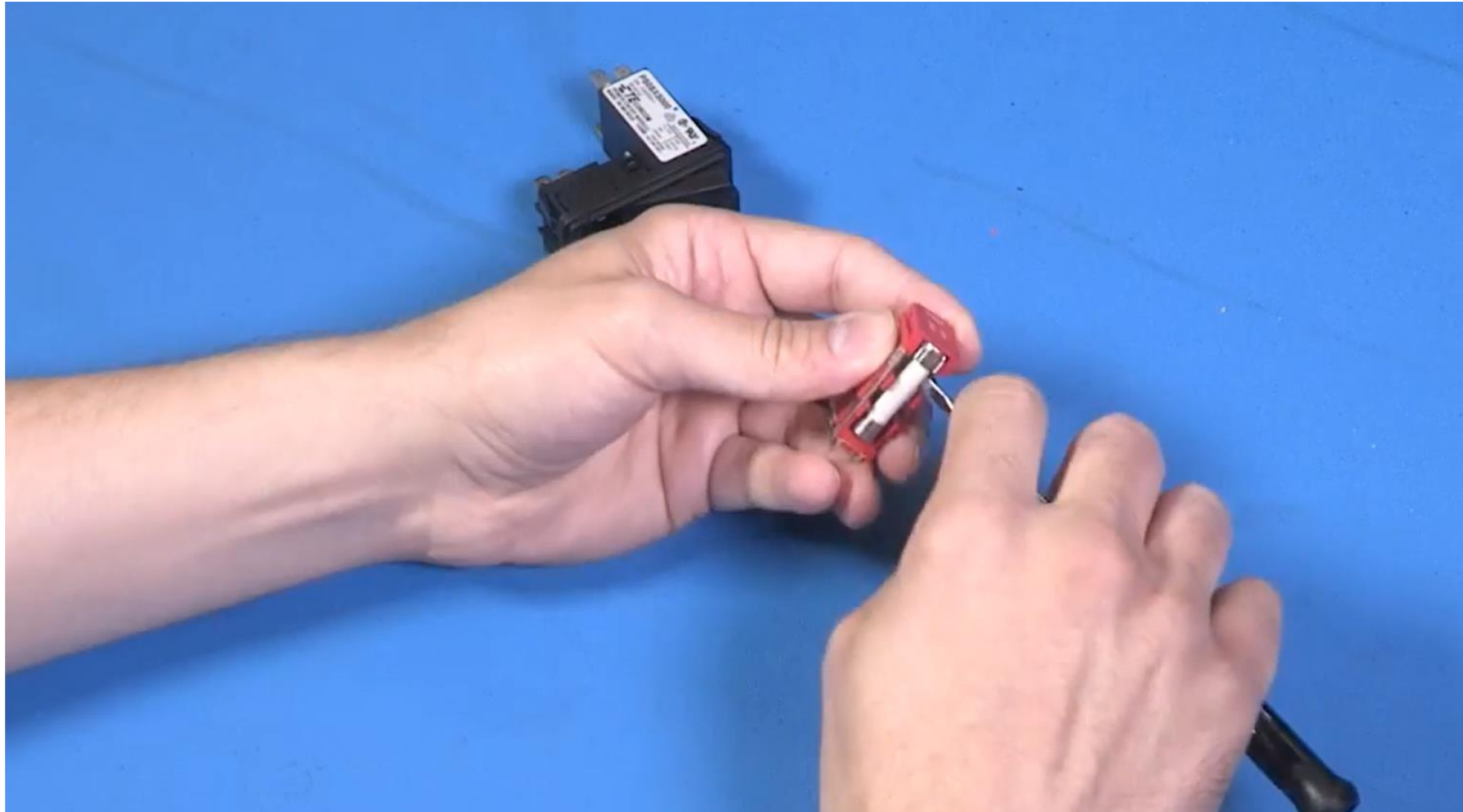

Figure 7. Fuse Being Removed (AC Model)

6.8 Detail of Fuse Installed (AC Model)



Figure 8. Detail of Fuse Installed (AC Model)