



User Guide

Frequency Distribution Amplifier

Model FDU-240

P/N 022000001

Revision C

March 2006

Brandywine Communications
1153 Warner Avenue
Tustin, CA 92780
(714) 755 1050
(714) 755 0175

<http://www.brandywinecomm.com/>



Revision History

REVISION	DATE	COMMENTS
NC	07-14-2004	Original release of FDU-240 user guide.
A	09-08-2004	Revision of entire FDU-240 user guide.
B	02-21-2006	Customer's comments incorporated into FDU-240 user guide.
C	03-21-2006	Added customer feedback page.

WARNING: This unit contains lethal AC voltages. Disconnect the unit from the AC supply before removing the cover.



WARNING:

The lightning flash with an arrowhead inside of an equilateral triangle is intended to alert the user to the presence of un-insulated “dangerous voltage” within the product’s enclosure. The “dangerous voltage” may be of sufficient magnitude to constitute as a risk of electrical shock to people.



CAUTION:

The exclamation point inside of an equilateral triangle is intended to alert the user to the presence of important operation and maintenance instructions in the user guide.



Table of Contents

1	Specifications	5
1.1	Inputs	5
1.1.1	Reference Frequency Input	5
1.1.2	Fault Discrete (Optional).....	5
1.1.3	Fault/Status	5
1.2	Outputs.....	6
1.2.1	Reference Frequency Output	6
1.3	Switches and Indicators	7
1.3.1	Status LED Indicators	7
1.3.2	Environmental.....	7
1.3.3	Power.....	7
1.3.4	Physical	7
2	Option Configuration Sheet.....	8
3	Unpacking and Installation.....	9
3.1	Unpacking	9
3.2	Installation	9
3.3	Connections	10
3.3.1	Alarm Input Connection	10
4	Operation	11
4.1	Powering the FDU-240	11
4.2	Selecting the Input Reference.....	11
4.3	Fault Indicator	11
5	Maintenance and Troubleshooting	12
6	Calibration.....	13
7	Drawings	14



1 Specifications

1.1 Inputs

1.1.1 Reference Frequency Input

- Frequency: 10 MHz \pm 0.5 ppm
- Amplitude : 0.5 V – 1 Vrms and nominal 1 Vrms factory set
- Input Impedance: 50 ohm
- Number of Inputs: 2 with auto selection and manual override from the front panel toggle switch
- Connector Type: BNC

1.1.2 Fault Discrete (Optional)

- Number of Inputs: 2
- Level: TTL
- Link selectable for active high or active low
- Forces a changeover when active for online reference

1.1.3 Fault/Status

- Connector Type: DB-9 Female
- Mating Connector: AMP P/N 747904-2

1.2 Outputs

1.2.1 Reference Frequency Output

- Number of Outputs: 24
- Connector Type: BNC
- Output Protection: short circuit proof
- Frequencies Available (same as input):
 - 10 MHz
 - 5 MHz
- Output Level: $+13 \pm 2$ dBm standard and specified at time of order
- Stability:
 - With External Reference Only:
 - + Same as reference
 - With Free Running Internal Oscillator:
 - + Stability vs. Temperature: $\pm 3 \times 10^{-9}$ from 0 - 60°C
 - + Aging: 5×10^{-7} per year
- Harmonic Distortion: -45 dBc
- Cross Talk: -80 dBc
- Spurious: -80 dBc
- Phase Noise at 10 MHz:

OFFSET (Hz)	SSB PHASE NOISE dBc/Hz
1	-90
10	-110
100	-140
1000	-150
10000	-160



1.3 Switches and Indicators

1.3.1 Status LED Indicators

- Power (Green)
- Reference Input A Available (Green)
- Reference Input A Online (Green)
- Reference Input B Available (Green)
- Reference Input B Online (Green)
- Automatic Reference Selection Selected (Green)
- Fault (Red)

1.3.2 Environmental

- Temperature:
 - Operating: -30 to +60°C
 - Storage: -40 to +85°C
- Humidity: 10 - 95% non-condensing

1.3.3 Power

- 115/230 VAC 50/60 Hz
- < 25 W

1.3.4 Physical

- 1.72" H x 14.5" D x 17.00" W and 1U 19" rack mount
- Weight: 7.5 lbs nominal



2 Option Configuration Sheet

FDU-240 CONFIGURATION SHEET			
PART NUMBER 022000001			
CONNECTOR	FUNCTION	LEVEL	INSTALLED
J1	ALARM INPUT		
	PIN 1 STATUS A	ACTIVE H_L ✓	✓
	PIN 2 STATUS B	ACTIVE H_L ✓	
	PIN 3 NO CONN		
	PIN 4 NO CONN		
	PIN 5 NO CONN		
	PIN 6 GROUND		
	PIN 7 GROUND		
	PIN 8 GROUND		
PIN 9 NO CONN			
J3	REFERENCE A INPUT	1.0 V _{rms}	✓
	FREQUENCY	10 MHz	
REFERENCE A SOURCE	EXTERNAL ✓ _____	FREE RUNNING OCXO _____	OCXO PHASE LOCKED TO REFERENCE _____
J2	REFERENCE B INPUT	1.0 V _{rms}	✓
	FREQUENCY	10 MHz	
REFERENCE B SOURCE	EXTERNAL ✓ _____	FREE RUNNING OCXO _____	OCXO PHASE LOCKED TO REFERENCE _____
J4 - J27	FREQUENCY OUTPUT	1.0 V _{rms}	✓
	LEVEL	10 ± 1 dBm	
AC POWER		115 VAC	✓

3 Unpacking and Installation

3.1 Unpacking

Carefully remove the FDU-240 from its shipping carton. The following items should be included in the shipment:

- 1 FDU-240
- 1 power cord
- 1 user guide

Note the power entry module on the rear of the FDU-240 chassis. Please take note of the voltage displayed on the rear of the power entry module and verify that the voltage matches the local line's voltage.



CAUTION:
THE FDU-240 WILL BE DAMAGED IF THE INCORRECT AC LINE SETTING IS USED.



WARNING:
REMOVE THE POWER CORD FROM THE FDU-240 BEFORE ADJUSTING THE LINE VOLTAGE.

If the AC line setting is incorrect, detach the power cord from the power entry module. Use a small screwdriver to lift up the fuse cover on the power entry module to remove the fuse holder. Reverse the fuse holder and re-insert the fuse holder, making sure that the correct AC line voltage is now displayed on the rear panel.

3.2 Installation

The FDU-240 should be bolted directly into a 19" rack mount enclosure or mounted on a shelf. The FDU-240 when fully populated has up to 27 cables attached to the rear panel, *therefore it is recommended that some appropriate cable strain-relief system be used to support these cables, particularly when the unit is not supported by a shelf.*

3.3 Connections

Insert the power cord provided in the shipment into the rear power entry module. Connect the input reference signals to the appropriate connectors on the rear panel.



CAUTION:
FOR CORRECT OPERATION, REFERENCE FREQUENCY A AND REFERENCE FREQUENCY B MUST BE THE SAME FREQUENCY, WHICH IS TYPICALLY 10 MHz.

Connect the output cables to the desired output connectors. Any unused connectors may be left un-terminated.

3.3.1 Alarm Input Connection

The FDU-240 may be used with an external reference such as the Brandywine Communications GPS8 or PTS system that incorporates a discrete alarm signal. This alarm signal is used to indicate a fault (e.g. rubidium out of lock) on the reference signal, although the 10 MHz input signals may be present.

The factory standard FDU-240 configuration is a logic HI signal on the ALARM IN pin indicating that the input is GOOD. A built in pull-up resistor ensures that if no ALARM IN connection is made the reference is considered good. To change the polarity of the ALARM IN, remove the top cover of the FDU-240 and set the links to the link settings seen in the table below.

LINK SETTING	REFERENCE A STATUS
LK1 2-3	HI – reference A is GOOD
LK1 1-2	LO – reference A is GOOD

LINK SETTING	REFERENCE B STATUS
LK2 2-3	HI – reference B is GOOD
LK2 1-2	LO – reference B is GOOD

4 Operation

Refer to Figure 1 for a guide of the front panel controls and indicators.

4.1 Powering the FDU-240

Once all connections to the FDU-240 have been made, apply power to the unit by placing the on/off switch to the on position. The on/off switch is located on the rear panel power entry module.

If an external reference is fitted, verify that the two green LEDs Reference A Available (1) and Reference B Available (2) are illuminated. This indicates that the FDU-240 has detected the presence of the external references.

Place the Reference Select Switch (3) in the center (AUTO) position. The green Reference A Online LED (4) and the AUTO LED (6) should illuminate. This indicates that the FDU-240 outputs will be driven from Reference A and if Reference A fails, it will automatically switch to Reference B.

If an internal oscillator is installed, allow 5 - 10 minutes for the initial warm up of the frequency reference. The FDU-240 is now ready for operation.

4.2 Selecting the Input Reference

The external reference frequency used is selected by the Reference Select Switch (3). Moving the switch to the left position will select input A as the reference. Moving the switch to the right position will select input B as the reference. The center (AUTO) position will use Reference A as the input if it is present and the status indicator indicates that it is good.

Either one or two internal oscillators may be installed. If one is installed, it is always installed as Reference A. To operate as a free running standard, leave the reference select switch in the left position.

4.3 Fault Indicator

The red LED on the front panel indicates that one or more of the outputs has a low signal. There are four potential causes for this as listed below:

1. There is no input signal or the internal OCXO (if fitted) has failed.
2. Input B has been manually selected and there is no input signal connected to reference Input B.
3. One or more output buffers have failed.
4. There is a short on an output cable.

5 Maintenance and Troubleshooting

There is no preventive maintenance required for the FDU-240.

SYMPTOM	POTENTIAL CAUSE	CORRECTIVE ACTION
No signal outputs	<ol style="list-style-type: none"> 1. There is no input reference. 2. The Reference Select switch is selecting Reference B when an internal OCXO is used. 3. There is a failed internal source. 	<ol style="list-style-type: none"> 1. Connect the reference input. 2. Select an internal source. 3. Return to factory for repair.
Fault light illuminated	<ol style="list-style-type: none"> 1. There is an internal OCXO failure. 2. There is a failed output driver. 3. There is an excessive load on one or more outputs. 4. The output level is adjusted too low. 	<ol style="list-style-type: none"> 1. Return to factory for repair. 2. Return to factory for repair. 3. Disconnect the output loads one by one until the overloaded output is isolated. Outputs should not have a load < 50 ohm. 4. Isolate the low output level and adjust for a level that is > 10 dBm.

6 Calibration

Calibration is only applicable to units fitted with a free running internal OCXO. The center frequency of the OCXO may be periodically adjusted to compensate for aging.

1. Remove the top cover of the FDU-240 and put it aside.
2. Identify the internal OCXO and remove the 4 - 40 screw that covers the calibration access hole.
3. Allow the unit to operate for 24 hours to allow the OCXO to fully stabilize.
4. Connect one of the 10 MHz reference outputs to a frequency counter with at least an **11 digit resolution**.



CAUTION:

The frequency counter **MUST** be configured to use an external reference such as a Cesium, Rubidium, or GPS disciplined OCXO as its time-base. The calibration accuracy of the FDU-240 can only be as accurate as the reference against which it is calibrated. It should be better than 1×10^{-10}

5. Using a very small screwdriver, insert it carefully into the OCXO adjustment access hole until it engages with the slot in the adjustment potentiometer. Slowly adjust the potentiometer until the frequency counter reads 10.000000000 ± 5 MHz.



7 Drawings

FIGURE	DESCRIPTION
1	FDU-240 Front Panel
2	FDU-240 Rear Panel
3	FDU-240 Mechanical Outline
4	FDU-240 Link Location



FDU-240
FRONT PANEL
FIGURE 1

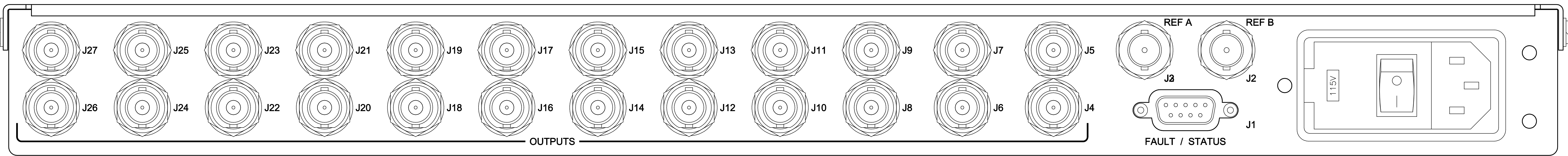

FDU-240
 REAR PANEL
 FIGURE 2

THIS DRAWING EMBODIES A CONFIDENTIAL PROPRIETARY DESIGN ORIGINATED BY BRANDYWINE COMMUNICATIONS. AND ALL DESIGN, MANUFACTURING, REPRODUCTION USE, AND SALE RIGHTS REGARDING THE SAME ARE EXPRESSLY RESERVED. IT IS SUBMITTED UNDER A CONFIDENTIAL RELATIONSHIP FOR A SPECIFIED PURPOSE, AND THE RECIPIENT AGREES BY ACCEPTING THIS DRAWING NOT TO SUPPLY OR DISCLOSE ANY INFORMATION REGARDING IT TO ANY UNAUTHORIZED PERSON, OR TO INCORPORATE IN OTHER PRODUCTS AND SPECIAL FEATURES REGULAR TO THIS DESIGN. ALL PATENT RIGHTS HERETO ARE EXPRESSLY RESERVED BY BRANDYWINE COMMUNICATIONS.
 © 2000 BY BRANDYWINE COMMUNICATIONS

REVISION				
REV	DESCRIPTION	DRFT	DATE	APPROVED

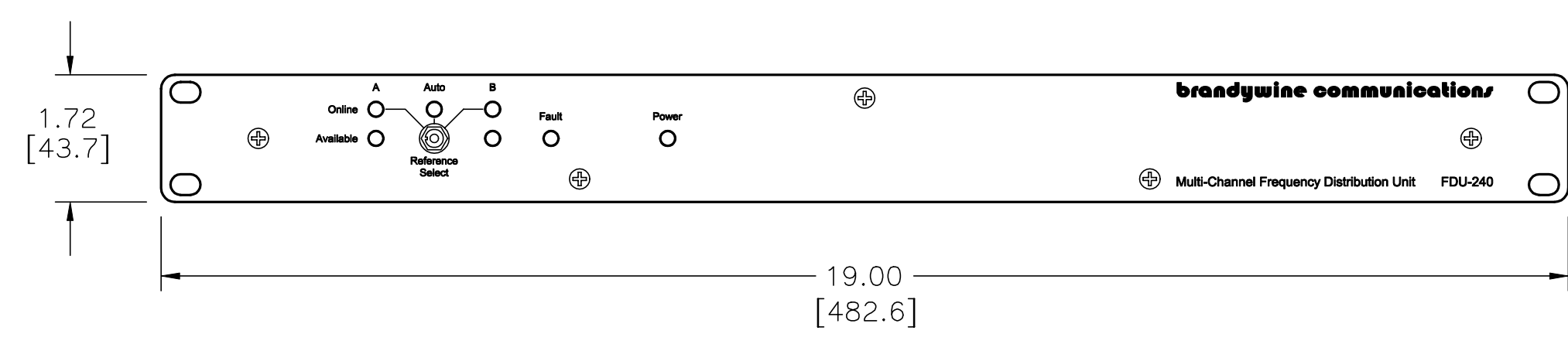
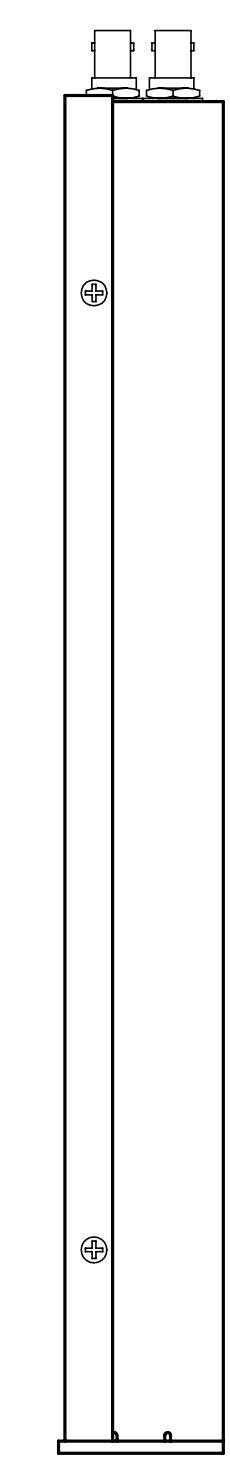
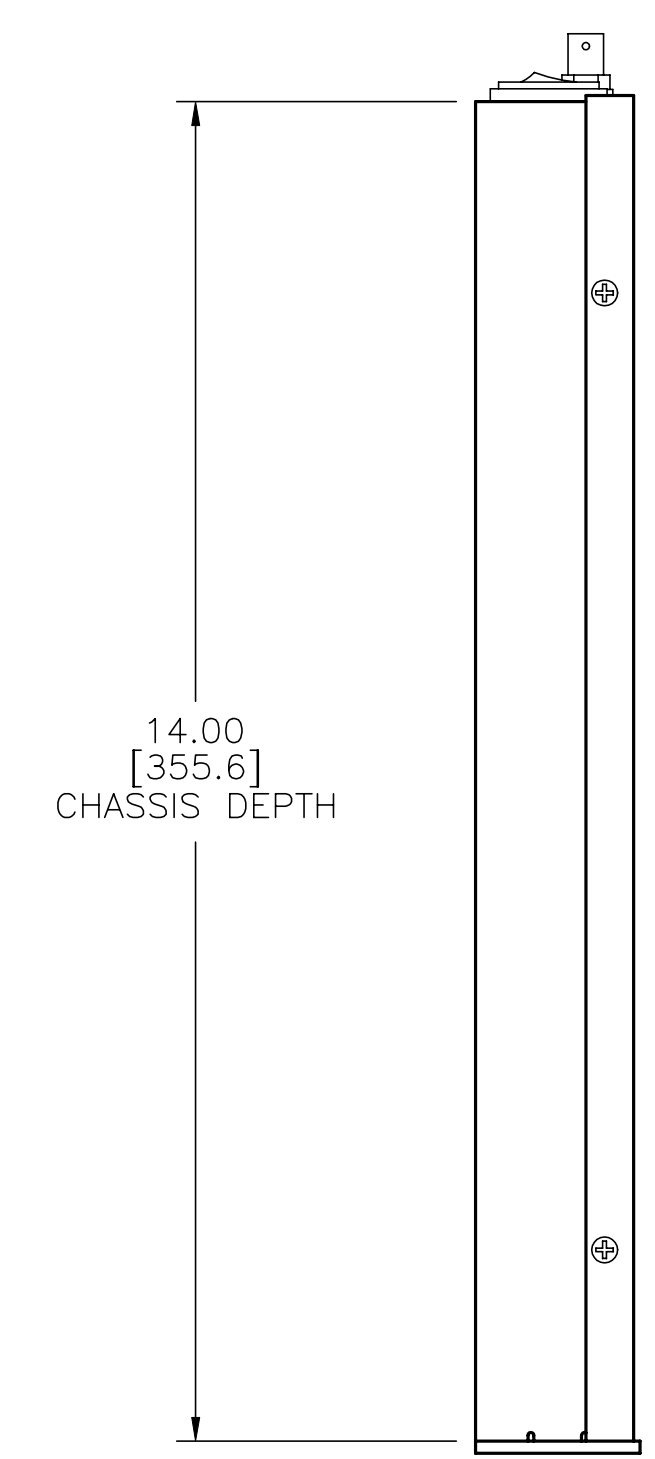
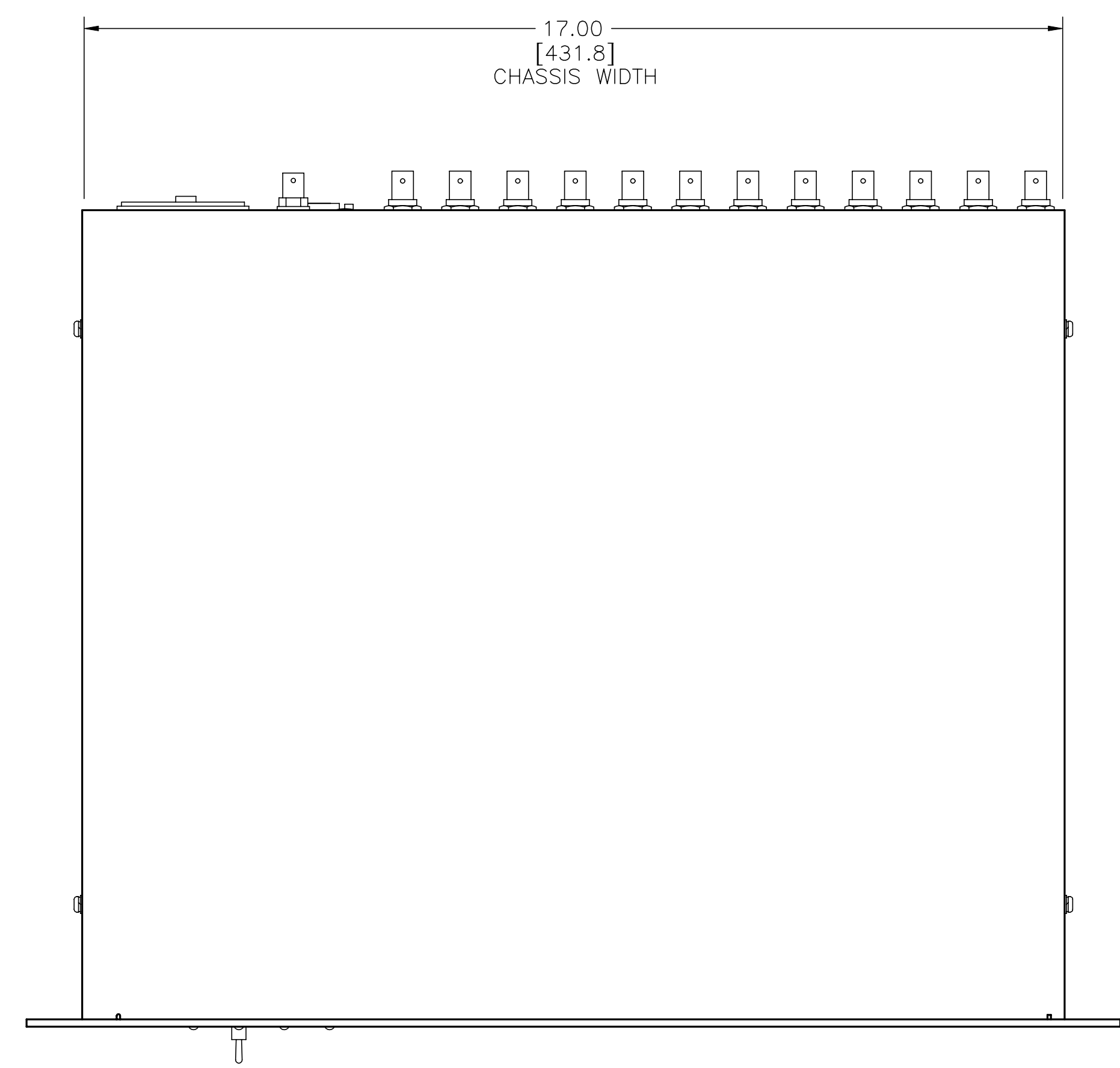
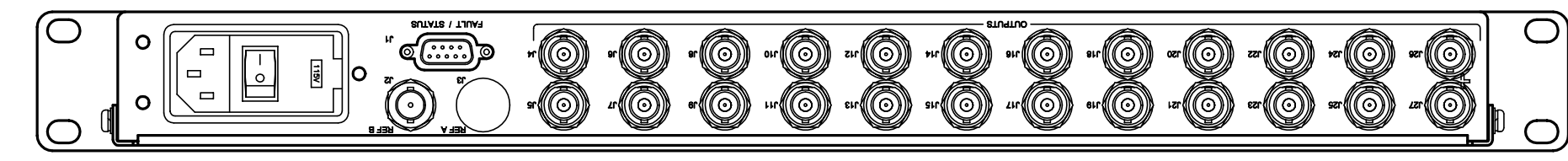

- WEIGHT: 6.5 POUNDS [2.9 KG] NOMINAL.
- DIMENSIONS ARE IN INCHES, DIMENSIONS IN BRACKETS ARE IN MILLIMETERS.

NOTE: UNLESS OTHERWISE SPECIFIED.

QTY REQD	ITEM NO.	PART OR IDENTIFYING NO.	NOMENCLATURE OR DESCRIPTION	MATERIAL	SPECIFICATION	CODE
UNLESS OTHERWISE SPECIFIED DIMENSIONS ARE IN INCHES			PROG/PROJ FDA-240	brandywine communications 2230 South Fairview, Santa Ana, California 92704		
DIMENSIONS APPLY AFTER FINISH			DRAWN Lind 7/15/04			
TOLERANCES			ENGINEERING GHS JUL 04	TITLE		
HOLE DIA± .XX ±				OUTLINE DRAWING		
ANGLES± .XXX ±				FDU-240		
MATERIAL				SIZE CAGE CODE DWG NO. REV		
FINISH				D 03NF8 850000016 N/C		
SURFACE ROUGHNESS √ ---				SCALE 1/2 DO NOT SCALE DRAWING SHEET 1 OF 1		

QTY	QTY	NEXT ASSEMBLY	USED ON
N/A	U/O		APPLICATION

4

3

2

1

850000016 N/C/B

A

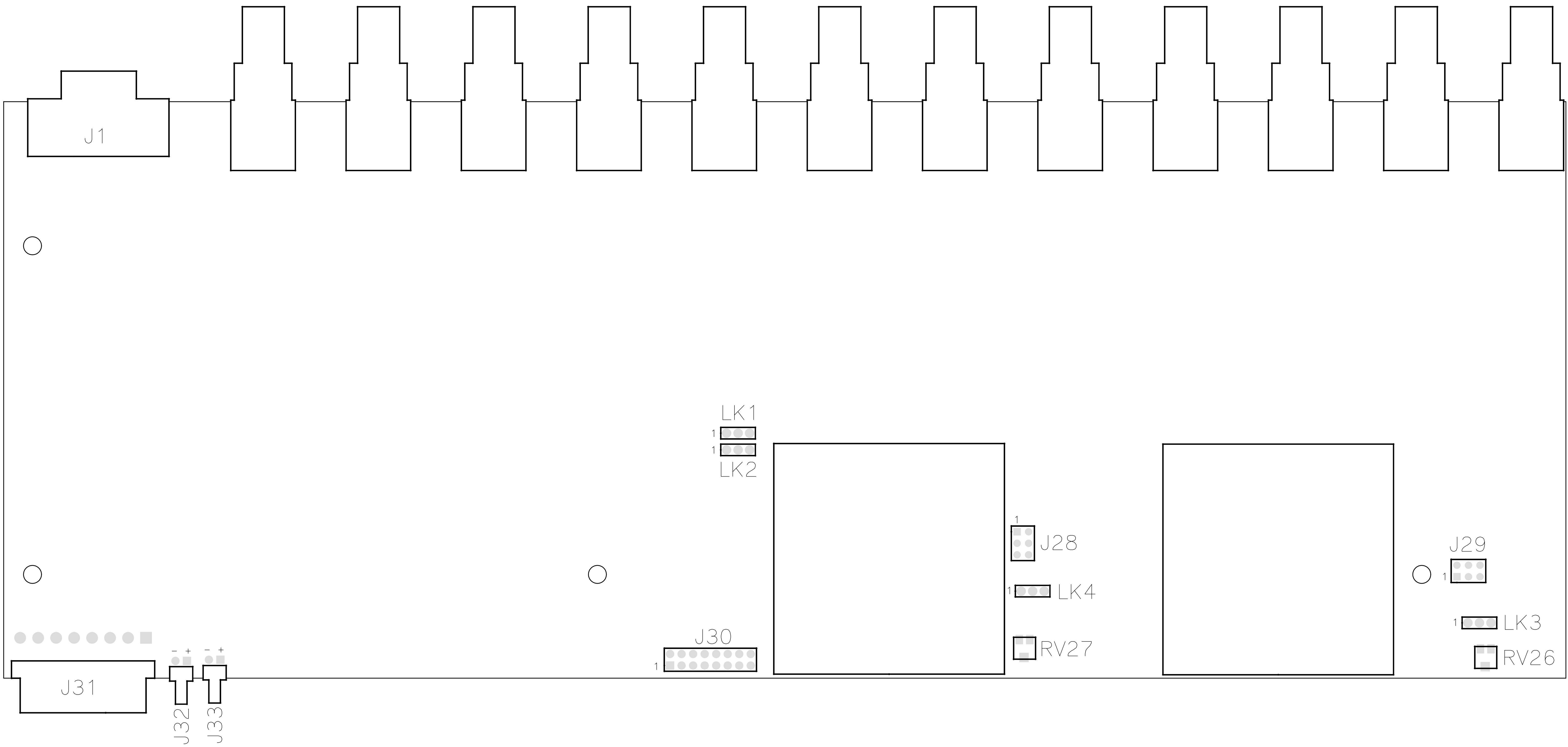



CUSTOMER FEEDBACK

1153 Warner Avenue
Tustin, CA 92780
714 755 1050 Tel
714 755 0175 Fax

Please take a moment to help us improve your experience with Brandywine Communications. When you're done, please either email this form to lisap@brandywinecomm.com or fax this form to 714 755 0175.

PRODUCT QUALITY

How would you rate our product?

- High quality
- Generally good
- Quality varies
- Poor quality

How would you rate our user guide?

- High quality
- Generally good
- Quality varies
- Poor quality

What product did you purchase?

Model# _____

Part# _____

Do you have any questions or concerns regarding our user guide? If so, please make note of them in the Additional Comments section.

- Yes
- No

ADDITIONAL COMMENTS

ABOUT YOU (OPTIONAL)

Name _____ E-mail _____

Address _____ Phone _____

City, State, Zip _____

THANK YOU FOR YOUR PARTICIPATION!